

Multi-Zones & Auto Mode

Auto Changeover alternates between heating or cooling if the room temperature falls 4°F below the set temperature when cooling or rises 4°F above the set temperature when heating. Auto changeover is not designed to provide rapid changes between heating and cooling operation or simultaneous heating and cooling. This feature is not recommended for systems with more than one indoor unit unless all indoor units have similar heating and cooling requirements and have similar temperature set points.

Inverter multi-zone units have one refrigerant system Fig. 1, and operation of each indoor unit should be harmonized with the primary settings. The first unit with the heating or cooling settings takes precedence. If an indoor unit is set to operate on a mode it can't perform or not in accordance with the primary settings, the OPERATON LED (Red) of the indoor unit will flash (1 second ON and 1 second OFF) and will go into standby mode.

EXAMPLE:

If indoor unit **(A)** was started in fan mode and then the indoor unit **(B)** was then operated in heating mode, indoor unit **(A)** would temporarily start operation in fan mode but when indoor unit **(B)** started operating in heating mode, the OPERATION indicator lamp (red) for indoor unit **(A)** would begin to flash (1 second on, 1 second off) and it would go into standby mode. Indoor unit **(B)** would continue to operate in heating.

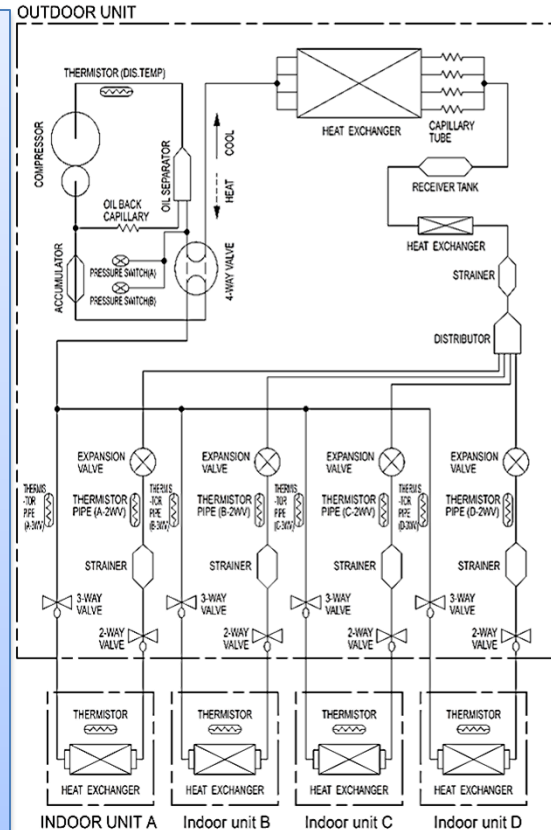

Not Permissible Mode Combination

Mode	•Heating (COIL DRY) mode and cooling mode (or dry mode)
	•Heating (COIL DRY) mode and fan mode

Permissible Mode Combination

Mode	•Cooling mode and dry mode
	•Cooling mode and fan mode
	•Dry mode and fan mode
	•Heating mode and COIL DRY mode

Disclaimer:

In order to perform some of these tests an electrical and/or refrigerant license is required. We strongly advise to check the Service manual for more detailed explanation. If you are not sure about these recommendations please contact us at 866-952-8324.