

# Bosch BVA 2.0 Series Air Handler

2-3-4-5 Ton Capacity

R410A



**BOSCH**

## Product Specifications





**Table of Contents**

<b>1</b>	<b>Product Features</b>	<b>4</b>
1.1	Features and Benefits	4
1.2	Warranty	4
<b>2</b>	<b>Nomenclature</b>	<b>5</b>
<b>3</b>	<b>Product specifications</b>	<b>6</b>
<b>4</b>	<b>Dimensions</b>	<b>7</b>
<b>5</b>	<b>Airflow Performance</b>	<b>8</b>
<b>6</b>	<b>Heater Kit Data</b>	<b>9</b>

## 1 Product Features

### 1.1 Features and Benefits

- ▶ Premium efficiency – Up to 20.5 SEER, up to 10.5 HSPF
- ▶ All aluminum evaporator coil for superior corrosion resistance
- ▶ Constant torque multi-speed ECM blower motor - designed for two stage operation
- ▶ 5, 8, 10, 15, 20 kW electric heat accessory kits available for supplemental or emergency heating needs
- ▶ Easy to install – compatible with most standard 24 VAC heat pump thermostats
- ▶ Factory-installed TXV metering
- ▶ Multi-position Installation - upflow or horizontal right standard; field convertible to horizontal left or downflow
- ▶ Multiple electrical entry locations
- ▶ Dual front panel design for ease of maintenance
- ▶ Blower and coil easy slide out for ease of maintenance
- ▶ Fully-insulated cabinet design
- ▶ Horizontal and vertical condensate drain pans standard
- ▶ Condensate drain pan is polymer with UVC inhibitor
- ▶ Primary and secondary condensate drain fittings
- ▶ Factory-sealed cabinet certified to achieve 2% or less air leakage rate at 1.0 inch water column
- ▶ Integrated filter rack with tool-less door access
- ▶ AHRI and ETL Listed

### 1.2 Limited Warranty

For Products installed in a one or two family residential dwelling, BTC warrants that all compressors and internal components incorporated into the Product at the time of shipment by BTC shall remain free from defects in workmanship and materials for ten (10) years\* from the Commencement Date. If the Warranty Registration process has been completed and BTC determines that the Product or any part of the Product has a defect in workmanship or materials, BTC shall pay labor charges associated with the repair or replacement of the part in accordance with the Warranty Labor Allowance Schedule\*\* for the period of ninety (90) days from the Commencement Date.

\* Please refer to [www.bosch-climate.us](http://www.bosch-climate.us) for full warranty terms and conditions.

\*\* Warranty Labor Allowance Schedule details are available on [www.boschprohvac.com](http://www.boschprohvac.com)

## 2 Nomenclature

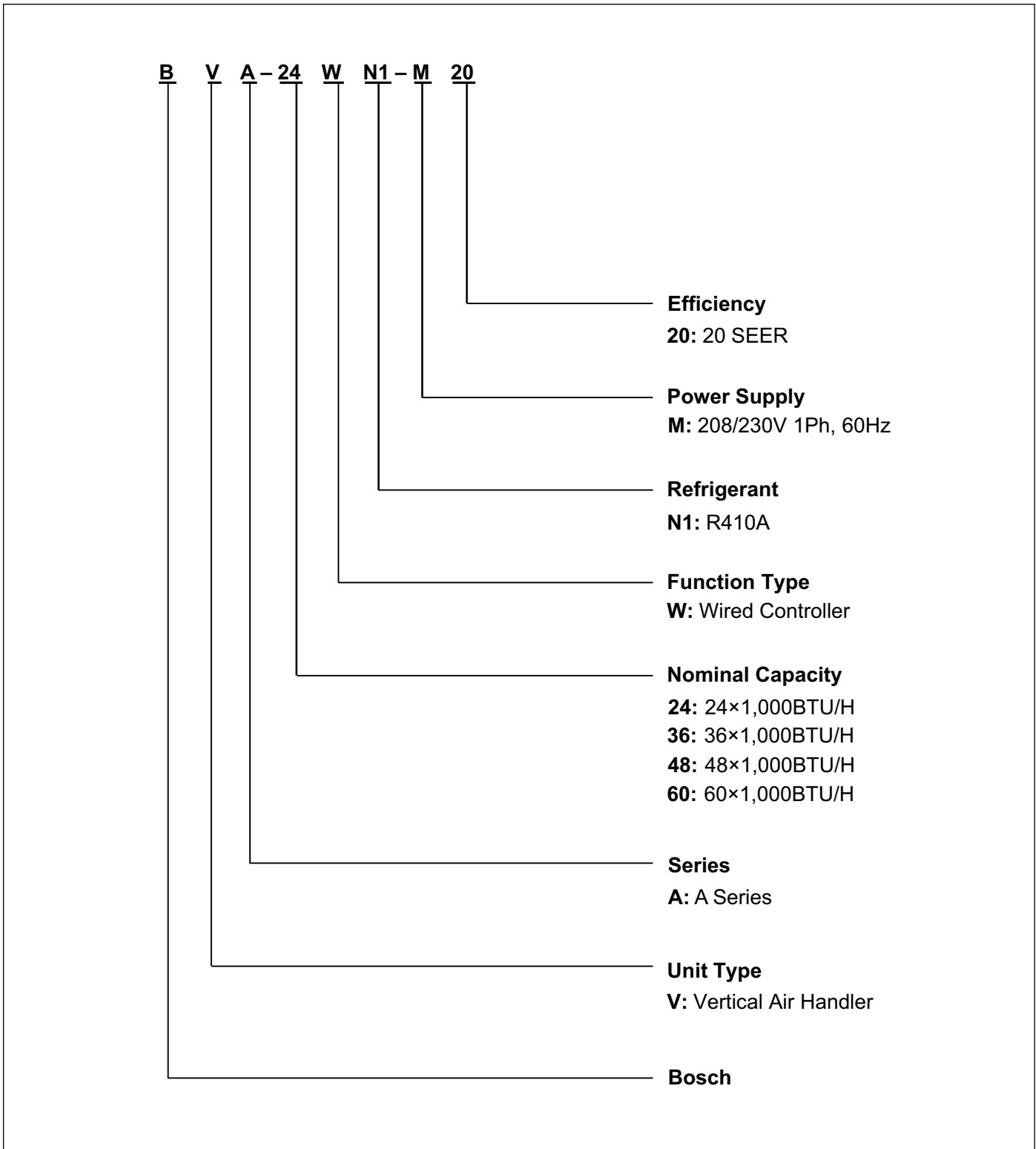

Figure 1

### 3 Product specifications

	BVA024	BVA036	BVA048	BVA060
<b>Cooling Capacity</b>				
Nominal Cooling (BTU/h)	24000	34600	47500	54500
Nominal Heating (BTU/h)	24000	34200	48000	56000
<b>Blower</b>				
Diameter (mm)	10-5/8" (270)	10-63/64" (279)	10-63/64" (279)	10-63/64" (279)
Width (mm)	8-5/32" (207)	10-43/64" (271)	10-43/64" (271)	10-43/64" (271)
<b>Fan Motor</b>				
Horsepower (HP)	1/3	1/2	3/4	3/4
Full Load Amps	2.6	3	4.5	4.5
<b>Refrigeration System</b>				
Refrigerant Line Size <sup>1</sup>				
Liquid Line Size (O.D.)	3/8"	3/8"	3/8"	3/8"
Suction Line Size (O.D.)	3/4"	3/4"	7/8"	7/8"
<b>Refrigerant Connection Size</b>				
Liquid Line Size (O.D.)	3/8"	3/8"	3/8"	3/8"
Suction Line Size (O.D.)	3/4"	3/4"	7/8"	7/8"
Expansion Device [TXV=Thermal Expansion Valve]	TXV			
<b>Decibels dB(A)</b>				
High Speed	63	65	67	68
Medium Speed	59	62	63	64
Low Speed	55	58	59	60
<b>Electrical Data</b>				
Voltage-Phase-Hz	208/230-1-60	208/230-1-60	208/230-1-60	208/230-1-60
Minimum Circuit Ampacity <sup>2</sup>	3.3	3.8	5.7	5.7
Max. Overcurrent Protection <sup>3</sup>	15	15	15	15
Min / Max Volts	172V/270V			
<b>Air Filter</b>				
Air Filter Sizes	18" x 20"	18" x 20"	20" x 22"	20" x 22"
<b>Weight</b>				
Net Weight (without packaging)(lbs)	119	124	154	161
Gross Weight (including packaging)(lbs) <sup>4</sup>	147	152	187	194
<b>Dimensions</b>				
Unit D x W x H (in.)	21-5/8 x 19-5/8 x 46-1/2	21-5/8 x 19-5/8 x 46-1/2	24 x 22 x 54-1/2	24 x 22 x 54-1/2
Unit D x W x H (in.)(with pallet and packaging)	25-3/8 x 22-5/16 x 52-9/16	25-3/8 x 22-5/16 x 52-9/16	27-11/16 x 24-11/16 x 60-5/8	27-11/16 x 24-11/16 x 60-5/8
<b>Indoor Coil</b>				
Net face area-sq.ft.	4.02	4.02	5.99	5.99
Tube diameter	9/32" (7 mm)	9/32" (7 mm)	9/32" (7mm)	9/32" (7mm)
No.of rows	4	4	4	5
Fins per inch	17	17	17	17

Table 1

<sup>1</sup> Tested and rated in accordance with AHRI Standard 210/240.

<sup>2</sup> Wire size should be determined in accordance with National Electrical Codes; extensive wire runs will require larger wire sizes.

<sup>3</sup> Must use time-delay fuses or HACR-type circuit breakers of the same size as noted.

<sup>4</sup> Weight shown includes packaging

### 4 Dimensions

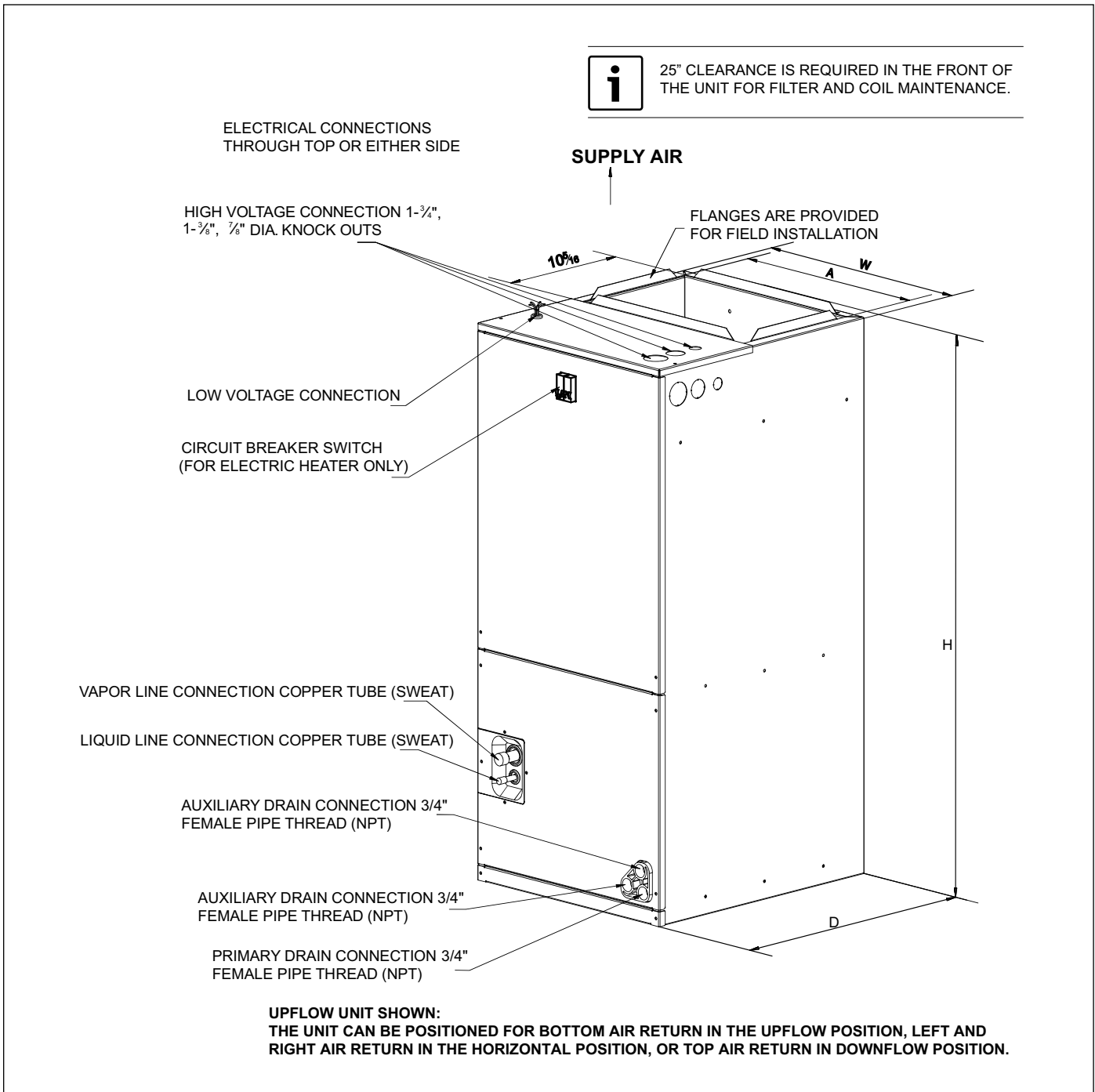

Figure 2

Model Size	Dimensions Inch [mm]				
	Unit Height "H"	Unit Width "W"	Unit Length "D"	Supply Duct "A"	Liquid Line / Vapor Line
24	46-1/2 [1180]	19-5/8 [500]	21-5/8 [550]	18 [456]	3/8 / 3/4 [9.5]/[19]
36	46-1/2 [1180]	19-5/8 [500]	21-5/8 [550]	18 [456]	3/8 / 3/4 [9.5]/[19]
48	54-1/2 [1385]	22 [560]	24 [610]	19-1/2 [496]	3/8 / 7/8 [9.5]/[22]
60	54-1/2 [1385]	22 [560]	24 [610]	19-1/2 [496]	3/8 / 7/8 [9.5]/[22]

Table 2

## 5 Airflow Performance

Airflow performance data is based on cooling performance with a coil and no filter in place. Check the performance table for appropriate unit size selection. External static pressure should stay within the minimum and maximum limits

Air Handler Model Size	Motor Speed		SCFM								
			External Static Pressure-Inches W.C. [kPa]								
			0[0]	0.1[.02]	0.2[.05]	0.3[.07]	0.4[.10]	0.5[.12]	0.6[.15]	0.7[.17]	0.8[.20]
24	Tap(5)	SCFM	1181	1144	1104	1063	1021	991	961	919	902
		Watts	263	274	283	289	298	304	314	323	328
	Tap(4)-Default High Stage Setting	SCFM	961	913	872	826	792	748	717	673	638
		Watts	146	151	160	166	175	180	190	195	205
	Tap(3)	SCFM	852	797	760	708	674	626	589	535	500
		Watts	109	114	122	127	137	142	150	155	157
	Tap(2)-Default Low Stage Setting	SCFM	755	711	653	615	563	505	499	413	382
		Watts	81	98	94	103	108	112	119	125	133
	Tap(1)	SCFM	712	647	604	548	490	481	452	427	368
		Watts	71	75	84	88	93	98	101	109	114
36	Tap(5)	SCFM	1460	1420	1371	1329	1228	1224	1195	1093	1041
		Watts	283	294	301	311	322	327	340	356	367
	Tap(4)-Default High Stage Setting	SCFM	1269	1213	1170	1121	1085	996	911	867	810
		Watts	191	197	207	213	223	238	247	255	266
	Tap(3)	SCFM	1152	1093	1046	988	895	829	764	717	707
		Watts	147	152	161	167	181	192	198	207	208
	Tap(2)-Default Low Stage Setting	SCFM	925	879	808	700	623	573	516	495	442
		Watts	87	96	100	111	116	125	129	134	143
	Tap(1)	SCFM	889	727	456	225	/	/	/	/	/
		Watts	74	66	51	44	/	/	/	/	/
48	Tap(5)	SCFM	2051	2006	1961	1914	1867	1819	1777	1735	1695
		Watts	454	471	487	503	518	531	545	559	572
	Tap(4)	SCFM	1914	1875	1831	1782	1735	1691	1649	1611	1581
		Watts	384	401	416	430	442	455	467	480	492
	Tap(3)-Default High Stage Setting	SCFM	1714	1661	1611	1560	1513	1469	1424	1380	1314
		Watts	273	289	304	317	330	343	353	366	386
	Tap(2)	SCFM	1499	1451	1398	1340	1288	1247	1188	1058	993
		Watts	198	212	224	234	243	256	271	290	303
	Tap(1)-Default Low Stage Setting	SCFM	1363	1307	1250	1181	1134	1062	938	875	835
		Watts	151	163	175	181	193	206	224	232	243
60	Tap(5)	SCFM	2029	1988	1947	1900	1858	1815	1771	1716	1671
		Watts	466	482	498	514	528	541	553	565	572
	Tap(4)-Default High Stage Setting	SCFM	1881	1843	1800	1754	1708	1666	1626	1590	1558
		Watts	391	407	423	438	449	462	474	487	498
	Tap(3)	SCFM	1677	1633	1586	1543	1499	1449	1409	1370	1281
		Watts	281	297	311	325	338	346	358	370	386
	Tap(2)-Default Low Stage Setting	SCFM	1491	1439	1380	1334	1285	1246	1180	1047	988
		Watts	205	217	226	238	250	259	269	292	300
	Tap(1)	SCFM	1348	1280	1227	1180	1130	1042	933	871	825
		Watts	157	165	176	187	196	206	225	233	245

Table 3

**□** Bold outlined areas represent airflow outside of the required 300-450 cfm/ton range.

NOTES:

- The high stage airflow must be used as the rated airflow for the full load operation of machine.
- The rated airflow of systems without electric heater kits requires between 300 and 450 cubic feet of air per minute (CFM).
- The rated airflow of systems with electric heater kits requires between 350 and 450 cubic feet of air per minute (CFM).
- The air distribution system has the greatest effect on airflow. Therefore, the contractor should use only industry-recognized procedures.
- Duct design and construction should be carefully done. System performance can be lowered dramatically through poor design or workmanship.
- Air supplier ducts should be located along the perimeter of the conditioned space and properly sized. Improper location or insufficient air flow may cause drafts or noise in the ductwork.
- Installers should balance the air distribution system to ensure proper quiet airflow to all rooms in the home. An air velocity meter or airflow hood can be used to balance and verify branch and system airflow (CFM).



## 6 Heater Kit Data

Heat Kit Model	Air Handler Model	(kW) Electric Heat	MIN. Circuit Ampacity		MAX. Fuse or Breaker (HACR) Ampacity		Fan speed				
			240 VAC	208 VAC	240 VAC	208 VAC	1	2	3	4	5
EHK-05B	24	5	29.4	25.9	30	30	●	●	●	●	●
EHK-08B		7.5	42.4	37.2	45	40	X	X	●	●	●
EHK-10B		10	55.4	48.5	60	50	X	X	●	●	●
EHK-05B	36	5	29.9	26.4	30	30	●	●	●	●	●
EHK-08B		7.5	42.9	37.7	45	40	X	●	●	●	●
EHK-10B		10	55.9	49	60	50	X	X	●	●	●
EHK-15B	48	15	55.9/26.1	49/22.6	60/30	50/25	X	X	●	●	●
EHK-05B		5	31.8	28.3	35	30	●	●	●	●	●
EHK-08B		7.5	44.8	39.6	45	40	●	●	●	●	●
EHK-10B	60	10	57.8	50.9	60	60	X	●	●	●	●
EHK-15B		15	57.8/26.1	50.9/22.6	60/30	60/25	X	X	●	●	●
EHK-20B		20	57.8/52.1	50.9/45.2	60/60	60/50	X	X	X	●	●
EHK-05B	60	5	31.8	28.3	35	30	X	X	●	●	●
EHK-08B		7.5	44.8	39.6	45	40	X	X	●	●	●
EHK-10B		10	57.8	50.9	60	60	X	X	●	●	●
EHK-15B	60	15	57.8/26.1	50.9/22.6	60/30	60/25	X	X	●	●	●
EHK-20B		20	57.8/52.1	50.9/45.2	60/60	60/50	X	X	X	●	●

Table 4 Suitable heat kits for AHU multi position installation

- Heat kit suitable for AHU 4-way position installation.
- Ampacities for MCA and Fuse/breaker including the blower motor
- Heat pump systems require a specified airflow. Each ton of cooling requires between 350 and 450 cubic feet of air per minute (CFM), or 400 CFM nominally.

### Heater Kit Accessories

Model	Description	24	36	48	60
EHK05B	5 kW Heat Kit, Double Pole Breaker	●	●	●	●
EHK08B	7.5 kW Heat Kit, Double Pole Breaker	●	●	●	●
EHK10B	10 kW Heat Kit, Double Pole Breaker	●	●	●	●
EHK15B	15 kW Heat Kit, Double Pole Breaker	X	●	●	●
EHK20B	20 kW Heat Kit, Double Pole Breaker	X	X	●	●

Table 5

[ ● means available, X means not available ]





**United States and Canada**

**Bosch Thermotechnology Corp.  
65 Grove St.  
Watertown, MA 02472**

**Tel: 866-642-3198  
Fax: 603-965-7581  
[www.boschheatingandcooling.com](http://www.boschheatingandcooling.com)**