



Ducted Systems Technical Services Service Tips Letter

Letter: **ST-001-2019**

Date: January 10, 2019

To: Ducted Systems (Factory Direct) S1 HVAC Branch Service, Sales, Warranty Managers
Ducted Systems (UPG/Applied) Distribution Service, Sales, Warranty Managers

Subject: **Obsoleted Replacement Service Heat Exchangers**

Product: 80% gas furnaces models: 6MG, AHU, BBU, BGD, BGM, BGU, FG8, G8C, GF8, GMB, GUA, GUB, L8C, MGP, ODF, P6UH, PADP, PAUP, UGA.

Effective: **January 10, 2019**

Expires: **January 10, 2022**

Summary: **This letter provides resolution for obsolete heat exchangers still covered by warranty.**

Heat exchangers for the above models have been obsoleted and in some cases, Source #1 stock of replacement heat exchangers may no longer be available. The model furnaces listed above typically carry a 20-year heat exchanger warranty, but in some cases are only 10 years. For clarification, the warranty terms for a failed heat exchanger is shown below.

UPG warrants the primary heat exchangers in the product to be free from defects in factory workmanship and material under normal use and service and will at its option, repair or furnish a replacement heat exchanger, either new or reconditioned, that meets the intended fit, use and function of the original heat exchanger for any heat exchanger furnished by UPG which proves to have such defects within the duration of warranty coverage. Alternatively, UPG may, at its option, extend a replacement allowance to be applied toward the purchase of a new furnace or packaged unit marketed by UPG. The exact amount of the allowance will be determined at the discretion of UPG, based upon current market conditions, but in no case shall this allowance exceed thirty (30) percent of the original consumer purchase price of the furnace, excluding such items as ductwork, wiring, piping and installation costs. UPG shall have no responsibility hereunder for installation, shipping, handling or other charges except as specifically provided herein.

The above-listed model furnaces typically contain a clam tube type heat exchanger as shown in the image below.

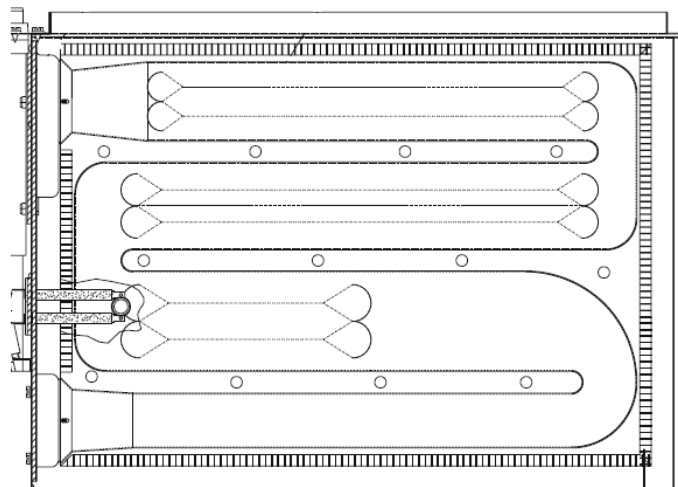

If a heat exchanger is needed to fulfill a warranty obligation for the above-listed models, place an order with Source #1. If a heat exchanger is not available but is in fact covered by the unit warranty, a concession request can be made through Source #1 or through residential distributor technical support.

Prior to a concession request, confirm the furnace is registered as installed and if not register it with the correct install date and consumer information so the appropriate warranty terms can be established. A concession (SI) may be issued for a \$200.00 credit to be used toward the purchase of a replacement UPG furnace. The replacement furnace will carry the balance of the warranty of the original unit and is eligible for consumer purchase of any applicable extended warranty coverage.

The rating plate from the old furnace must be kept for auditing purposes.

Please follow these procedures when filing a warranty claim for a replacement furnace once a concession has been issued:

1. File a parts, labor and change out claim.
2. Reference this service tips letter ST-001-2019 on the warranty claim
3. Reference the Service Inquiry (SI) number provided by Ducted Systems.
4. Select unit change out and enter the new unit serial number and date of installation.

If you have any questions on this feel free to call Ducted Systems Residential Technical Services at 1-877-874-7378 and speak with a technical support representative.



Casey McConaughy
Associate Product Technical Support Engineer
Residential Distributor Support
Ducted Systems Technical Services
Johnson Controls