

# INSTALLATION MANUAL

## TOUCH SCREEN COMMUNICATING CONTROL

MODELS: S1-TTSCC



### LIST OF SECTIONS

<b>GENERAL</b> .....	<b>2</b>
<b>SAFETY CONSIDERATIONS</b> .....	<b>2</b>
INSPECTION .....	2
LIMITATIONS .....	2
<b>INSTALLATION</b> .....	<b>3</b>
LOCATION .....	3
MOUNTING THE TOUCH SCREEN COMMUNICATING CONTROL .....	4
REMOVING CONTROL MOUNTING BACK PLATE .....	5
<b>WIRING COMMUNICATION</b> .....	<b>6</b>
WIRING REQUIREMENTS .....	6
SYSTEM WIRING OVERVIEW .....	6
HUMIDIFIER CONNECTION .....	13
<b>INITIAL POWER-UP</b> .....	<b>16</b>
POWER-UP SEQUENCE (SYSTEM MASTER) .....	16
SYSTEM CONFIGURATION .....	17
<b>ENTERING SERVICE MODE</b> .....	<b>20</b>
SERVICE MODE ON MASTER CONTROL .....	20
NAVIGATING SERVICE MODE: MASTER CONTROL .....	20
FORCED OPERATION: MASTER CONTROL .....	37
SERVICE TOOL SETUP .....	39

## SECTION I: GENERAL

The Touch Screen Communicating Control is designed to manage communicating system components (including: heat pumps, air conditioners, air handlers and furnaces). In general, these components are the variable speed modulating furnace, 2-stage variable speed ECM furnace and variable speed air handler, premium 15 and 18 SEER air conditioners or premium 13, 15 and 18 SEER heat pumps.

While the communicating system has been designed for easy installation, this document will provide the installer with a more detailed explanation of installation process.

## SECTION II: SAFETY CONSIDERATIONS



This is a safety alert symbol. When you see this symbol on labels or in manuals, be alert to the potential for personal injury and equipment damage.

Understand and pay particular attention to the signal words **DANGER**, **WARNING**, and **CAUTION**.

**DANGER** indicates an **imminently** hazardous situation, which, if not avoided, **will result in death or serious injury**.

**WARNING** indicates a **potentially** hazardous situation, which, if not avoided, **could result in death or serious injury**.

**CAUTION** indicates a potentially hazardous situation, which, if not avoided **may result in minor or moderate injury**. It is also used to alert against unsafe practices and hazards involving only property damage.

## INSPECTION

The following list details the parts included in this kit. Examine the kit to insure that all parts are included.

Item	QTY.	Description
1	1	Touch Screen Communicating Control
2	1	Communicating Plug Harness
3	1	Screw and Anchor Hardware bag
4	1	USB Adapter
5	1	Installation Instructions
6	1	Owner's Manual
7	1	Quick Help Document
8	1	Warranty Certificate
9	1	Warranty Registration Card

## LIMITATIONS

The Touch Screen Communicating Control's primary function is to command a system containing communicating product.

Exceptions to this rule are:

- Installing a communicating variable speed modulating furnace with a non-communicating air conditioner. In this case the variable speed modulating furnace relays 24 VAC outputs to the non-communicating air conditioner (per communicated commands by the Touch Screen Communicating Control).
- Installing communicating controls in non-communicating UPG products.
- Installing Communicating Interface Control (which converts communicating commands into 24VAC outputs).

## SECTION III: INSTALLATION

The intention of this document is to ensure proper connection/setup of the various communicating system components. These instructions should be used in conjunction with the instructions provided with indoor, outdoor and accessory equipment of which the Touch Screen Communicating Control will command.

This installation instruction contains (in part) setup, operation, and troubleshooting of the UPG Communicating System.

The Touch Screen Communicating Control will engage the installer with special screen prompts and introduce settings to simplify and provide a path through the initial start up of the system.

When Installing this Product...

1. Read all instructions carefully before beginning installation. Failure to follow these instructions can create hazardous situations or damage the product.
2. Make certain the product is suitable for your application by checking all ratings on the product and in the instruction provided.
3. Installer must be a trained, experienced service technician.

### LOCATION

Install the Touch Screen Communicating Control at or around 5 ft. (1.5m) above the floor in an area with good circulation of room temperature. See Figure 1.

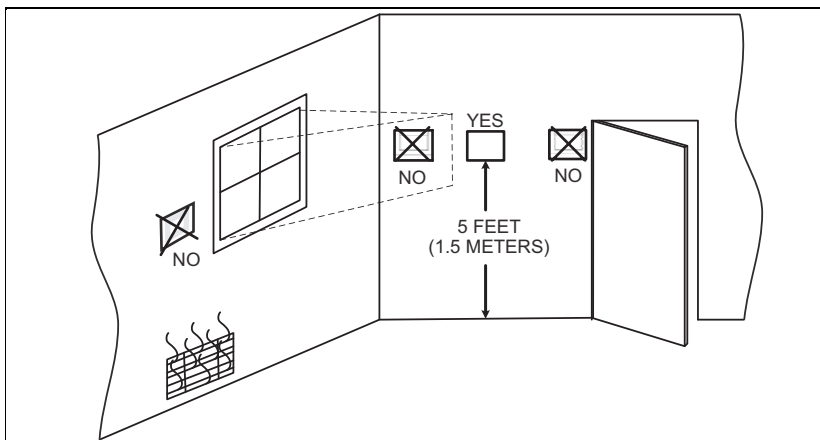

**FIGURE 1: Control Location**

Do not install the Touch Screen Communicating Control where it can be affected by:

- Drafts or dead spots behind doors and in corners
- Hot or cold air from ducts
- Radiant heat from sun or appliances
- Concealed pipes and chimneys
- Unconditioned areas such as an outside wall

## MOUNTING THE TOUCH SCREEN COMMUNICATING CONTROL

For most installations, mounting Touch Screen Communicating Control can be done following some very basic installation steps outlined below. However, there may be some cases where the installer is not able to penetrate the wall where mounting the Touch Screen Communicating Control, or there may be an application where the thermostat/control being replaced has left a larger hole than needed for installation of this control. For these and other applications, (including installation with a vertical j-box) an installer can obtain a Decorative/Mounting Kit (S1-02815909000).

### **WARNING**

**Voltage Hazard:** Live wires can cause electrical shock or equipment damage. Disconnect power before beginning installation.

1. If an existing thermostat or control is being replaced:
  - a. Remove existing control from wall.
  - b. Disconnect wires from existing control.
  - c. Properly discard or recycle old control.

### **NOTICE**

*Mercury is a hazardous substance, if existing thermostat or control contains any mercury, it MUST be disposed of properly. The Touch Screen Communicating Control does not contain mercury.*

2. Mark on the wall where the Touch Screen Communicating Control will be mounted (standard height is 5 feet from the floor).

### **NOTICE**

*If an existing thermostat was in place, it may be ideal to use the same location for the Touch Screen Communicating Control.*

3. Cut a 2" x 2" square hole with the bottom of the square at the mark.

### **NOTICE**

*Make sure that the hole is cut so that the Touch Screen Communicating Control can be leveled when mounted. See Figure 2 for more detailed mounting information.*

4. Using the mounting back plate as a template, mark the screw holes on the surface where mounting the Touch Screen Communicating Control. Use a level to insure proper installation.

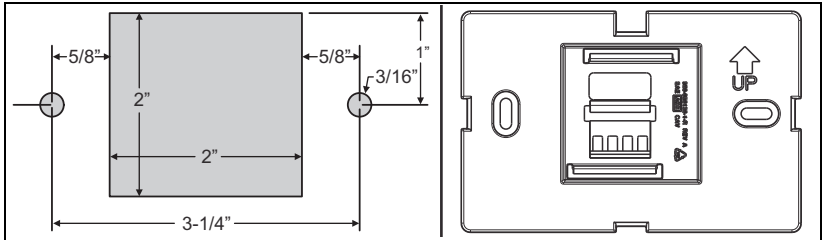

**FIGURE 2: Mounting Back Plate Dimensions**

5. Remove mounting back plate.
6. Drill holes (3/16" in diameter) in the marked area to accommodate the anchors (provided in the kit).
7. Place anchors in the pre-drilled holes. Be sure that the anchors are fully inserted.
8. Pull low voltage wires through the mounting back plate as shown in Figure 3.

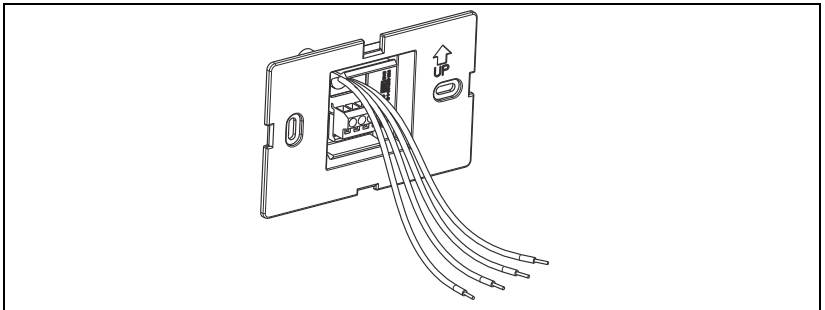

**FIGURE 3: Wires Pulled Through Mounting Back Plate**

9. Connect low voltage wires as instructed in the wiring section of this document.

### IMPORTANT

*Fastening the wires in the terminal block before attaching the back plate to the wall will ultimately ease the installation of the wire. Once on the wall, the terminal block has limited accessibility.*

10. Screw the wired mounting back plate to the wall using the screws provided in the kit.
11. Align the terminal screw block with the pins on the back of the Touch Screen Communicating Control and snap it to the mounting back plate.

### REMOVING CONTROL MOUNTING BACK PLATE

Gently remove by tilting up to release the bottom of the Touch Screen Communicating Control and then pull out/down to completely remove.

## SECTION IV: WIRING COMMUNICATION

All wiring must comply with local electrical codes and ordinances. Refer to Table 1 for terminal designations.

**TABLE 1: Terminal Designations**

Signal	Definition	Label
Data	Non-inverted signal	A (+)
Low voltage power hot	24 VAC (Hot)	R
Low voltage power common and data ground	24 VAC (Common)	C
Data	Inverted signal	B (-)

### WIRING REQUIREMENTS

Standard 18 awg thermostat wires can be used to connect the communicating system.

Special (shielded) cable is not typically required. As with all communicating devices, it is a good idea to keep wiring at least one foot away from large inductive loads. Examples of large inductive loads include: electronic air cleaners, motors, etc. If these wiring practices are ignored, it may introduce electrical interference (noise) which can cause erratic system operation.

#### NOTICE

*There may be installation applications where large inductive loads cannot be avoided. In these cases shielded wire would be desired to ensure proper system functionality.*

### SYSTEM WIRING OVERVIEW

#### IMPORTANT

*The communicating system requires 4 wires to operate. If installing a communicating system, be sure to supply at least 4 wires to each unit/control. Below is a simple diagram showing the ideal wiring path.*

The system is connected by four wires. Two of the wires are used to bring power into the individual controls (R and C) and two of the wires are used for serial communication (A+ and B-). The plug/harness that is provided in the kit should be used on the outdoor control.

Each Touch Screen Communicating Control Kit is equipped with a Communicating Plug Harness (Fig. 5). This wire harness should be used for the wiring of the outdoor unit.

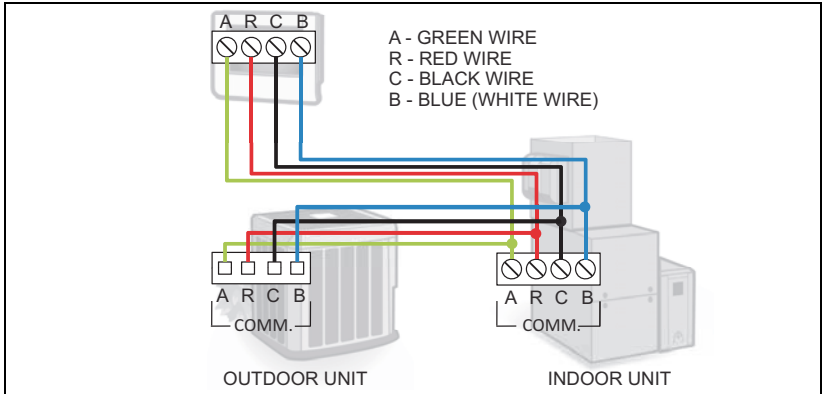

FIGURE 4: High Level Wiring Path

## NOTICE

*A pig tail of no more than 6 inches coming out of each device terminal.*

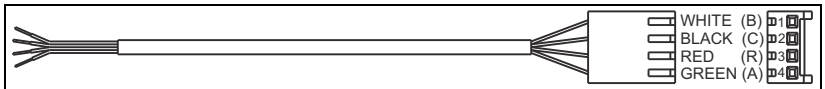

FIGURE 5: Communicating Plug Harness

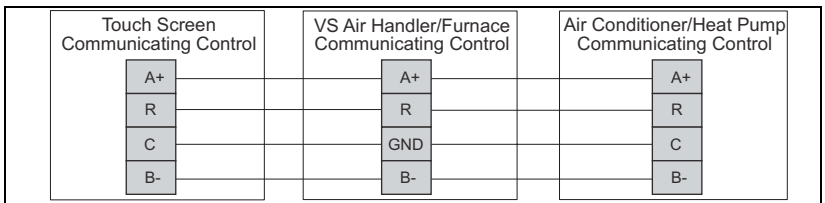
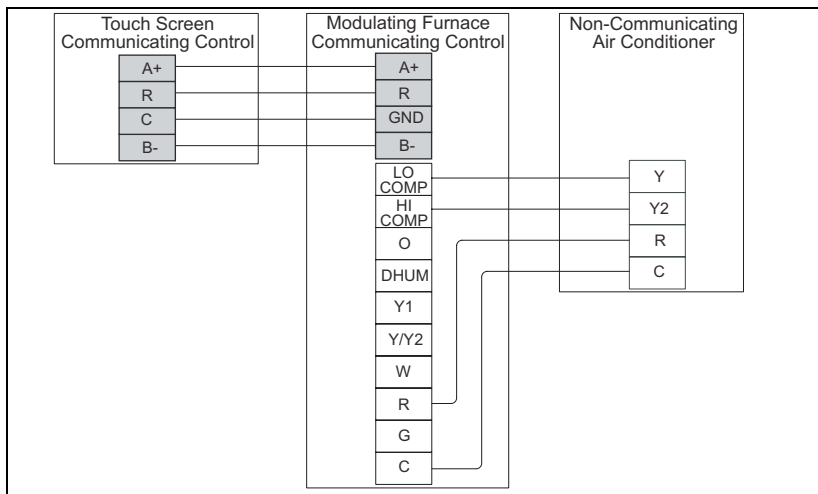

FIGURE 6: Wiring Diagram (Fully communicating system components)



**FIGURE 7:** Wiring Diagram Communicating Furnace, Non-Communicating AC

### **Touch Screen Communicating Control Wiring**

#### **⚠ WARNING**

##### ***ELECTRICAL OPERATION HAZARD***

*Failure to follow this warning could result in personal injury, death, or equipment damage. Before installing, modifying, or servicing system, the main electrical disconnect switch must be in the OFF position. There may be more than 1 disconnect switch. Lock out and tag switch with a suitable warning label.*

1. Turn off all power to equipment.
2. Loosen the screws in the terminal block of the mounting back plate.
3. Match and connect thermostat wires to proper terminals on Touch Screen Communicating Control mounting back plate.
4. Push any excess wire back into the wall.

#### **NOTICE**

*Plugging the hole in the wall with nonflammable insulation can help prevent drafts from adversely affecting temperature control.*

5. Once wires are secured, the mounting back plate can be placed on the wall as previously outlined.



## Outdoor Control Wiring

A new communicating heat pump or air conditioner (denoted by a “-C” in the model number) will have two communicating plug terminals (as shown in Figure 8).

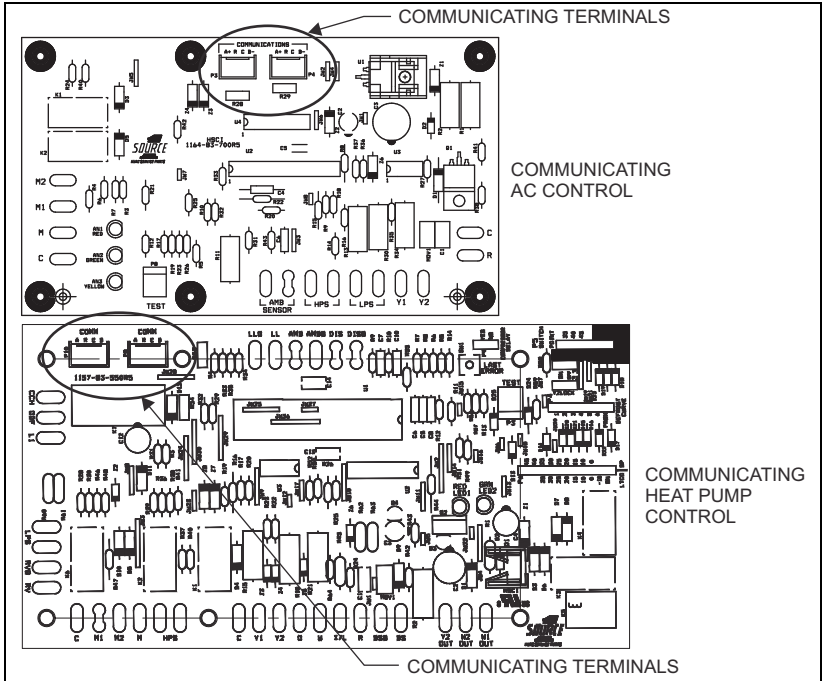

FIGURE 8: Outdoor Communicating Terminals

### **▲ WARNING**

#### **ELECTRICAL OPERATION HAZARD**

*Failure to follow this warning could result in personal injury, death, or equipment damage.*

*Before installing, modifying, or servicing system, the main electrical disconnect switch must be in the OFF position. There may be more than 1 disconnect switch. Lock out and tag switch with a suitable warning label.*

1. Disconnect all power from system (including high and low voltage).
2. Remove factory installed low voltage harness.
3. Plug the communication harness provided in the Touch Screen Communicating Control Kit (S1-TTSC0\*) into the communication port on the outdoor control.

- Wire nut thermostat wire (from the indoor control) to the communication harness wires.

**NOTICE**

*When connecting the loose ends of the wire harness, be sure to note color for each of the four wires (A+, R, C, B-).*

- Set the wires which are now connected (with wire nuts) into the Junction Box of the control housing (pictured below).

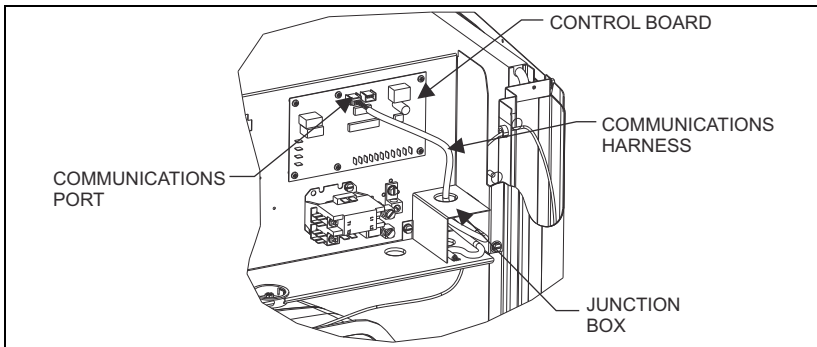

**FIGURE 9:** Outdoor Control Housing

- Set the appropriate jumper settings to insure proper control functionality (See table below).

Unit Control	Jumpers which must be set
Heat Pump	Fossil Fuel Hot Heat Pump
Air Conditioner	No Jumpers to set

**NOTICE**

*Jumpers listed here are required and if set incorrectly will flag an error upon installation. While the other jumpers can be set from the Touch Screen Communicating Control, it is good practice to initially set all jumpers at the respective control. This will avoid any confusion that may occur with future service at the units.*

**NOTICE**

*For installation of a non-communicating outdoor unit with the Touch Screen Communicating Control, the installer should reference the indoor and outdoor unit installation instructions. If information is not provided, there may be a need for a Communicating Interface Control Field Kit (S1-33102953000).*

## Indoor Control Wiring

A communicating furnace or air handler (denoted by a “C” in the model number) will arrive with a control outfitted for communication. The communicating indoor controls will have two communicating terminals. One will be a communicating plug input and the other will be a screw terminal (as shown below in Figure 10).

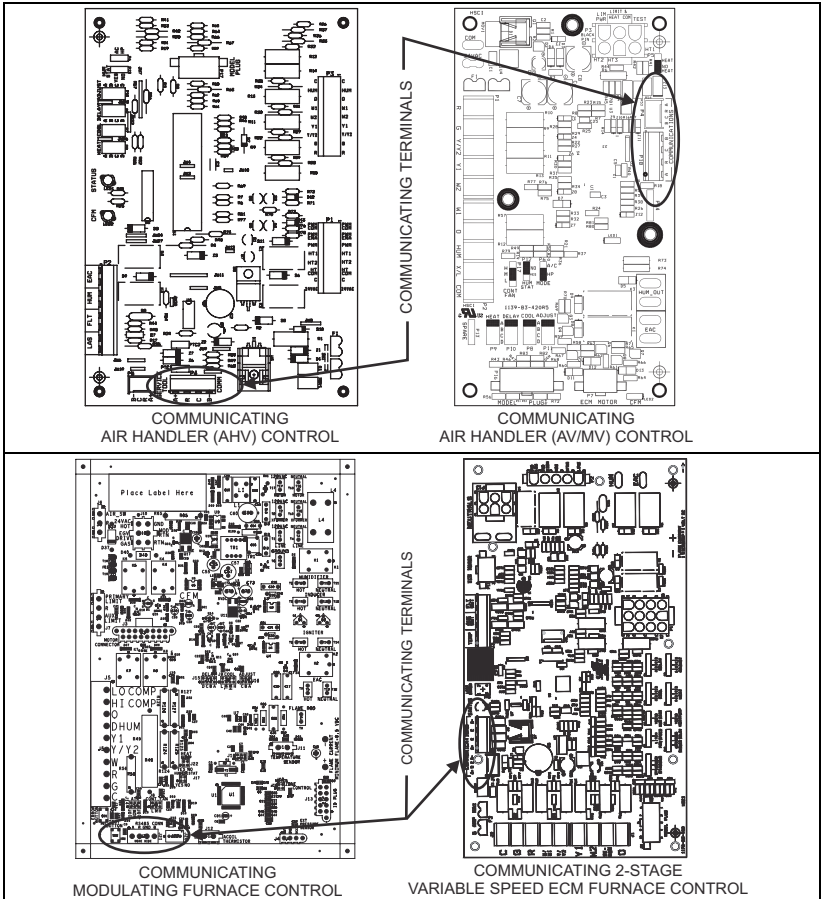

**FIGURE 10: Communicating Indoor Controls**

**WARNING****ELECTRICAL OPERATION HAZARD**

Failure to follow this warning could result in personal injury, death, or equipment damage. Before installing, modifying, or servicing system, the main electrical disconnect switch must be in the OFF position. There may be more than 1 disconnect switch. Lock out and tag switch with a suitable warning label.

1. Disconnect all power from system (including high and low voltage).
2. Screw the 4 wires from the Touch Screen Communicating Control and outdoor control to the communicating screw terminal (8 wires in all). Be sure that all wires are connected respectively (A+ = A+, R = R, C = C, B- = B-).

**NOTICE**

If the installer finds that the indoor control screw terminals are presenting a challenge, wire nuts can be used to connect the controls on the outside of the indoor unit.

**NOTICE**

The furnace control may be labeled so that C = GND.

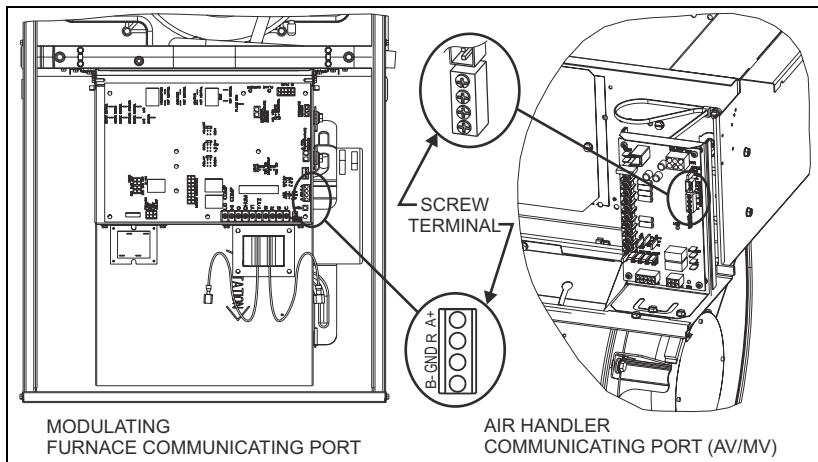

**FIGURE 11:** Indoor Screw Terminal Location

3. Set the appropriate jumper settings to insure proper control functionality (See table below).

Unit Control	Jumpers which must be set
Modulating Furnace	Heat Pump Humidistat Zone Control
Air Handler (AHV)	No Jumpers Required
Air Handler (AV/MV)	Heat/No Heat AC/HP Hum Stat
2-Stage Variable Speed Furnace	No Jumpers Required

### NOTICE

*Jumpers listed here are required and if set incorrectly will flag an error upon installation. While the other jumpers can be set from the Touch Screen Communicating Control, it is good practice to initially set all jumpers at the respective control. This will avoid any confusion that may occur with future service at the units. The Hum Stat jumper on the air handler must be set to "YES".*

### NOTICE

*For installation of a non-communicating indoor unit with the Touch Screen Communicating Control, the installer should reference the indoor and outdoor unit installation instructions. If information is not provided, there may be a need for use of an Communicating Interface Control Field Kit(S1-33102953000).*

## HUMIDIFIER CONNECTION

A bypass or fan powered humidifier may be installed with the communicating system. The installer should physically install the humidifiers according to the instructions that are included with the humidifier being installed. For information on the wiring of the humidifier, see below diagrams.

### NOTICE

**Do Not Use** a traditional humidistat to control humidifier operation. If a humidifier is installed, the Touch Screen Communicating Control will operate humidifier.

## Bypass Humidifiers

### Communicating Furnace

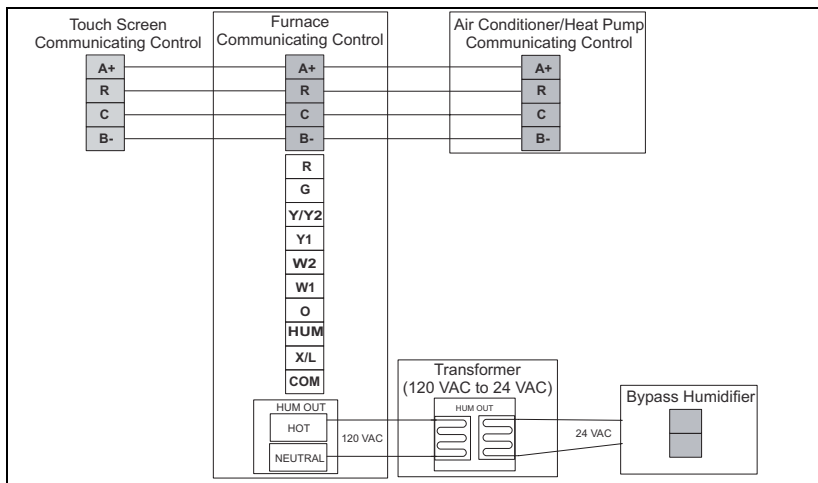

FIGURE 12: Furnace Bypass

### Communicating Air Handler

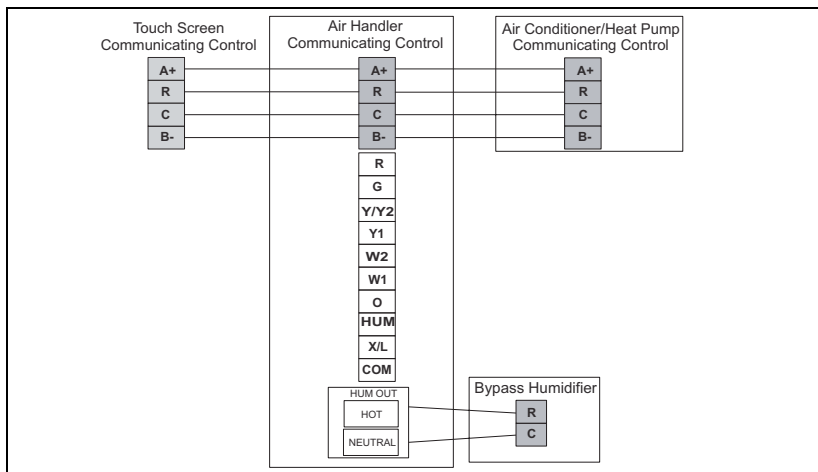

FIGURE 13: Air Handler Bypass

## Fan Powered Humidifiers

### Communicating Furnace

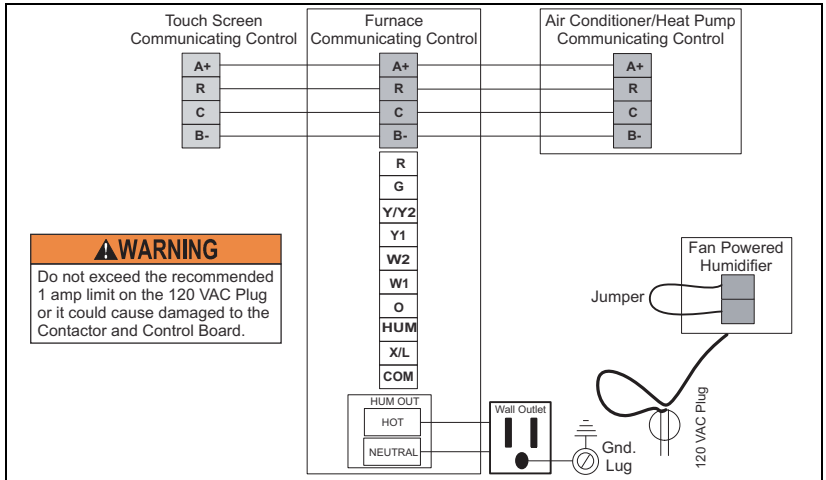

FIGURE 14: Furnace Fan Powered

### Communicating Air Handler

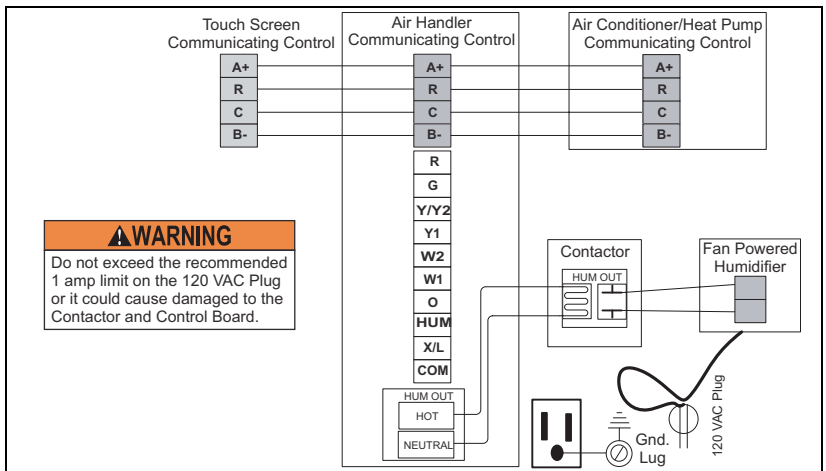

FIGURE 15: Air Handler Fan Powered

## SECTION V: INITIAL POWER-UP

**CAUTION**

*Failure to follow this caution may result in equipment damage.  
Do not power the system until you have confirmed that the wiring has been completed correctly (per this document).*

Before applying power, check to make sure that all wiring has been completed as instructed through the installation instructions of the equipment on the system.

Once power is applied, the installer should return to the thermostat to complete the installation process.

## POWER-UP SEQUENCE (SYSTEM MASTER)

The Touch Screen Communicating Control will guide the installer through the set up process. The following screens will load upon initial power up:

Press the box to highlight and modify using the up/down arrows

The up/down arrows control the "Date" and "Clock"

Press the "12 hr" or "24 hr" to display standard or Military Time

Press "Yes" or "No" to observe Daylight savings

## SCREEN 1 - Set date and time

**NOTICE**

*If daylight savings is selected, on the second Sunday of March the clock will change from 1:59 am to 3:00 am. Likewise, on the first Sunday in November the clock will change from 1:59 am to 1:00 am*

**SCREEN 2** - The control will Display Software Revision on the screen to insure that you are installing a control with the most up to date software.

**SCREEN 3** - The control will "listen" for network traffic for a random interval between 1-10 seconds.

**SCREEN 4** - The control "gathers" system information (including indoor and outdoor system components).





### SCREEN 5 - Set Control "Mode"

#### SYSTEM CONFIGURATION

After selecting the "System Master Mode" button, the Touch Screen Communicating Control will begin a routine to "discover" system components. The installer will be directed through screens (Auto Setup) that are dependent upon the system being configured. The below screens will appear dependent on equipment being installed.

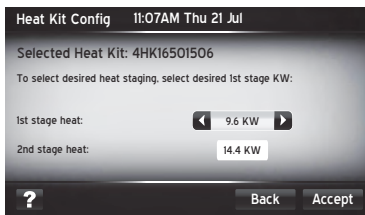
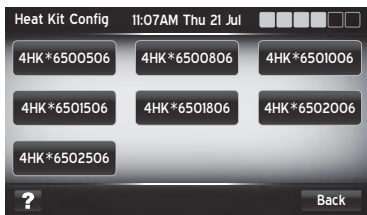

Heat kit configuration screens will appear in a communication system that includes a communicating variable speed air handler (indicated by a "C" in the model number). For the AV/MV Air Handler, the heat jumper must be located in the "On" position. For more information on the function of these screens refer to the Service Mode section of this document.

## NOTICE

*The screen shown above is representative only. Actual heat kit models may vary.*

## IMPORTANT

*If you have a system which has a heat kit installed, but did not see the heat kit configuration screens, be sure to check the air handler control to insure that the heat kit jumper is on "Heat". This only applies to the AV/MV Air Handler.*

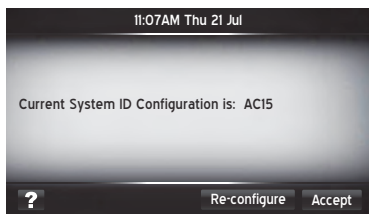

System ID screen will appear in every communicating system install. This screen displays the system ID that is used to identify system operation. For more information about the system ID and how the system will operate refer to Communicating Wiring Diagrams located on UPG-net.com.

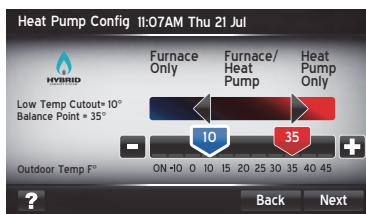
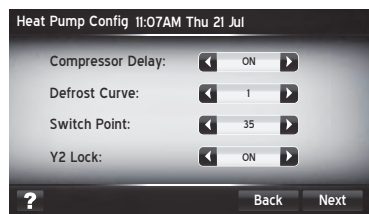

Heat Pump Configuration screens are only available in systems which contain communicating heat pumps (denoted by a "-C" in the model number). For more information on the function of these screens refer to the Service Mode section of this document.

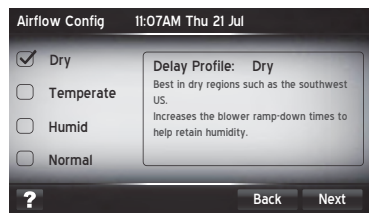

The Airflow Configuration screen is only available on a system that contains a variable speed communicating indoor unit (denoted by "-C" in the model number). For more information on the function of this screen refer to the Service Mode section of this document.

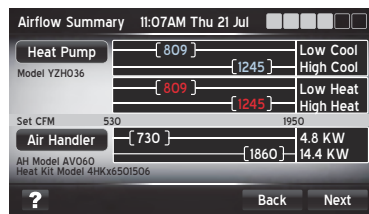

The Airflow summary screen is only available on a system that contains a variable speed communicating indoor unit (denoted by "-C" in the model number). The screen will be populated depending on the system being installed. For more information on the function of this screen refer to the Service Mode section of this document.

## NOTICE

*The modulating furnace airflow during heating is still controlled by the ignition control not the Touch Screen Communicating Control.*



The Edit/Add Devices screen is shown for every system install. For the system to properly control accessories, they must be “ADDED” using this screen. The information displayed will depend on the system being installed. Accessories such as humidifiers, EAC, and UV lights are not communicating, and model and serial numbers can be manually entered. For more information on the function of this screen refer to the Service Mode section of this document.

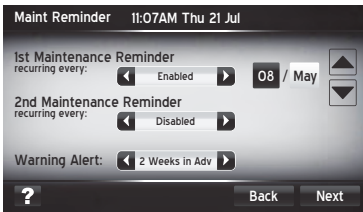

Maintenance Reminder screen is shown for every system install. Annual Maintenance Reminder can be entered by enabling the reminder and selecting the desired day and month. These are set up as you choose based on your business plan (i.e., do you want the homeowner to call for maintenance or not?). Two maintenance reminder events may be established (fall and spring).

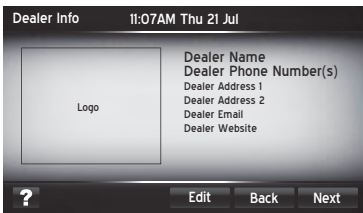

The Dealer Information screen is shown for every system install. This screen is for dealer information entry. Text can be entered with the keyboard or imported. For more information on the function of this screen refer to the Service Mode section of this document. This is the final setup screen. Once completed you can exit service mode for normal operation.

**NOTE:** For more information see “Navigating Service Mode: Master control” under SECTION VI of this document.

## SECTION VI: ENTERING SERVICE MODE

### SERVICE MODE ON MASTER CONTROL



The master control is a Touch Screen Communicating Control that has been configured to assume full control of a communicating system. To enter the service portion of the control press and hold (for 5 seconds) on the brand symbol located in the upper right hand side of a given screen (see picture).

Once in the service mode, the thermostat background will be gray (as pictured below) and the control can access system settings/information. The master has access to all areas of the communicating system.

### NAVIGATING SERVICE MODE: MASTER CONTROL



From the system map (as shown) the controller provides access to view all communicating components and settings. Press the icon that relates to the part of the system that you would like to access and the controller will view each communicating component's: Equipment Details, Equipment Status, and Inputs/Outputs. Below is a description of each of these screens.

#### **Equipment details:**

The equipment details screen displays fixed information which may include: System ID, Model number, Serial number and other details that pertain to the selected communicating equipment.

#### **Equipment status:**

The equipment status screen displays more dynamic information which may include: equipment state, timers, temperatures, fault codes, and other statuses that pertain to the selected communicating equipment.

#### **Equipment inputs/outputs:**



The inputs/outputs screen displays system commands which may include: thermostat input signals, control output signals and other input/outputs that pertain to the selected communicating equipment.

## NOTICE

*On each of the described screens there is a "Refresh" button. This button can be used to update the information on the screen to make sure all of the information being displayed is current.*

### **Accessories Button:**



From the system map the accessories button can be pressed. Here any additional accessories that have been added to the system can be viewed. This would include IAQ products such as ERV/HRV, dehumidifiers, etc.

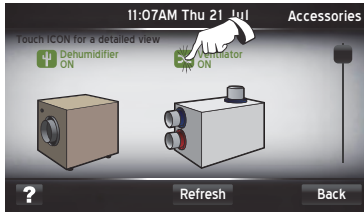

The details of the accessories are viewed by pressing the respective accessory icon.

### **Log Button: Master Control**

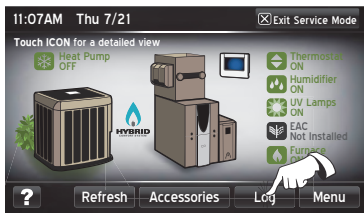

From the system map, the "Log" button can be pressed. Here the event and fault log screen can be viewed. This screen displays maintenance reminders, custom log entries, and faults.

## Viewing Details of a Log Entry



Pressing an entry displayed on the “Log” screen will prompt a screen that contains a more detailed description of the fault, event, alert, etc.

## Viewing/Filtering Displayed Log Content

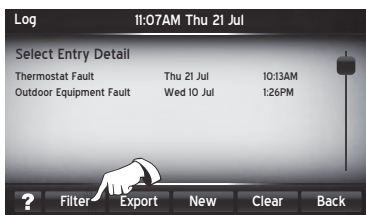

Press the filter button to narrow down the entries being displayed. The log entries displayed can be sorted by: All, Faults, Events, Custom, TSTAT, Inside, and Outside. See list below for more information.

**All:** Will display the full list of entries available on the system.

**Faults:** Will display all faults that have occurred on the communicating system.

**Events:** Will display all maintenance reminders and alerts that are not categorized as a fault.

**Custom:** Will display custom entries that have been manually input.

**TSTAT:** Will display all faults, alerts, and events that pertain to the Touch Screen Communicating Control.

**Inside:** Will display all faults, alerts, and events that pertain to the indoor communicating equipment.

**Outside:** Will display all faults, alerts, and events that pertain to the outdoor communicating equipment.

## Exporting Log File



Press the Export button to export the displayed log information. Using this function gives the user the ability to save the log of a Touch Screen Communicating Control for future reference.

If the export function is selected the user will be prompted to insert a USB device. Once the device is inserted, the Touch Screen Communicating Control will export the log information.

**NOTICE**

*Do not remove the USB device until prompted.*

**Clearing a Log Entry**

Press the Clear button to delete all of the displayed log entries. When the clear button is pressed, the Touch Screen Communicating Control will delete the log entries per the sort selection. For example, if "All" is selected in the sort screen, all of the log entries that have been saved on Touch Screen Communicating Control will be cleared (deleted).

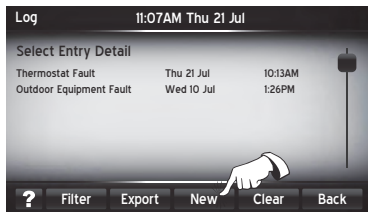
**New Event Entry**

Press the "New" button to create a new log entry. When the "Edit" button has been pressed the keyboard will pop up to allow the user to manually input a log entry. This can be used to keep track of home service, visits, maintenance, etc. For example, the user can check to see when the last A-Coil cleaning had taken place (if entered at time of cleaning).

**Service-Menu Button: Master Control**

From the system map, the "menu" button can be pressed. Here the main system menu is displayed (shown below).

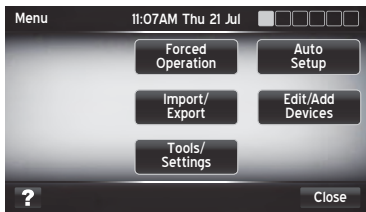

**Import/Export:**

The import/export screen allows the user to import and export through the mini USB port located on the bottom side of the thermostat (pictured). To access the port, use the mini USB to USB adapter (S1-03102965000) provided in the Touch Screen Communicating Control kit attached to a USB memory drive.

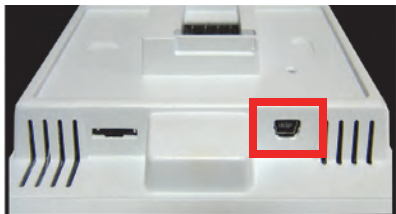
**NOTICE**

*Most USB drives are compatible with the Touch Screen Communicating Control. However, if you have questions as to which USB memory drives are approved for the Touch Screen Communicating Control, see [UPGnet.com](http://UPGnet.com) for more information.*

The USB can be used to import and export:

- Program Schedule

If the "Program Schedule" is selected, the control will import/export the setting of the program schedule (including: Schedule name, day, part times, and temperatures).

- Dealer information

If the "Dealer Information" is selected, the control will import/export the dealer information (Including: address, number, name, etc.)

- Dealer logo

If the "Dealer Logo" is selected the control will import/export the dealer logo (or picture).

- Homeowner configuration File

If the "Homeowner Configuration" is selected, the control will import/export the sound, display, schedule, security, View/Mode, etc. In short, it will be all homeowner settings including the personalized schedules.

- Installer configuration file

If the "Installer Configuration" is selected, the control will import/export every file available on the Touch Screen Communicating Control. Including the Homeowner settings, programmed schedules, dealer information, etc.

**Auto Setup**

Auto setup is used to view the installer system configuration screens that the installer was originally directed through. These screens will vary depending on the installed components.

**NOTICE**

*Auto setup screens are described in more detail in other sections of this document.*



## Edit/Add Devices

Edit/Add devices screen is used to add accessories/upgrades to the communicating system. These accessories/upgrades may include: heat pump, air conditioner, filters, humidifiers, UV lights, etc. Adding equipment through this screen will allow the control to provide maintenance updates and track any changes to the system. It will also ensure proper system functionality. Accessories must be added using this screen to enable the functionality of the Touch Screen Communicating Control for each accessory.

### To add a device:

## NOTICE

*Follow the installation instructions provided with the equipment being installed. For wiring instructions of Humidifier, see the wiring section of this document.*



1. Select from one of the options on the main, edit/add devices screen (see picture).

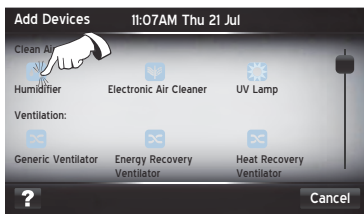

2. Once "Add Device" is selected the possible devices to add will be loaded for selection. Select the icon that represents the device being added (In this case humidifier).

## NOTICE

*Some of the device icons that are shown may not be used unless the communicating accessory board has been installed.*

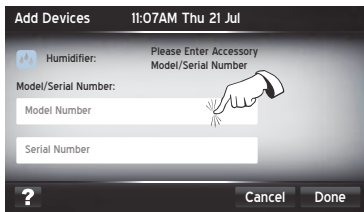

3. The next screen allows the user to add a model and serial number to the device details for future reference. Simply press the space that indicates "Model Number" or "Serial Number". This will activate the keyboard for input.

**NOTICE**

*This information is **not** required for SYSTEM OPERATION.*

- When all desired information has been entered, press the “Done” button in the lower right hand corner of the screen.
- The user will be prompted as to whether or not to save the settings. Press Yes if all information is entered as desired, or No if there is editing needed.

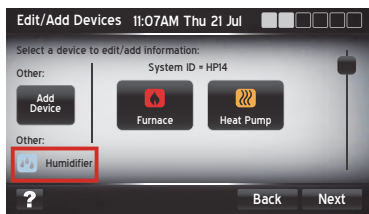

- Once saved, the device will display on the main edit/add devices screen.

**To remove a device:**

- Select a device that is available on the main “Edit/Add Devices” screen. This will display the model and serial number of the device that has been entered.
- At the bottom of the screen there is a button that says “Remove Device”.
- Another screen will confirm that the device is to be removed. Press “Yes” to remove the device or “No” to view the model and serial number screen.

**IMPORTANT**

*In some cases, the Touch Screen Communicating Control will need to be reset for the changes to take place.*

**Tools and Settings**

The tools and settings screen displays all of the available system settings (including settings on the individual communicating controls).

**System Settings**

Depending on the equipment that has been installed, the system settings screen will display different user options. These settings will determine how the Touch Screen Communicating Control will command the installed equipment. The settings pertain to installed equipment as well as general thermostat control settings. The Touch Screen Communicating Control is highly adaptable; the installer should consider all the available settings to maximize usability and comfort provided by the communicating controls (the settings are described in the following sections).

**NOTICE**

*The options explained in this document may or may not be available on your communicating system. They depend on installed components.*

## Heat Kit Configuration

This screen is available if there is a variable speed air handler with the addition of an approved heat kit. Here the heat kits approved for the installed air handler will be displayed (and the current selected heat kit will be highlighted). If there has been a change in the originally installed heat kit, the installer **MUST** use this screen so that the appropriate air flows will be applied during heat kit operation.

### IMPORTANT

*If the heat kit selected does not match the heat kit installed, the Touch Screen Communicating Control may apply air flow values that can cause nuisance limit trips or cold blow.*

## Heat Pump Configuration

These screens are available if there is a communicating heat pump control installed. These screens allow heat pump “jumpers” to be changed from the Touch Screen Communicating Control.

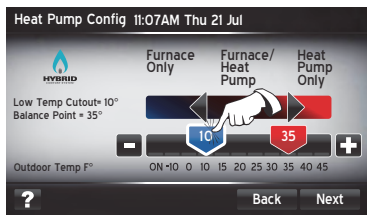

**Compressor Delay:** (ON, OFF) Compressor Delay will turn the compressor off for 30 seconds immediately after energizing the reversing valve (in defrost). The purpose is to reduce noise in defrost.

**Defrost Curve:** (1-6) Defrost Curve is set in the factory and should only be changed in a repair part installation

**Switch Point:** (35, 40, 45) Switch Point is the temperature of the liquid line sensor (in Fahrenheit) at which the heat pump will force 2<sup>nd</sup> stage operation.

**Y2 Lock:** (ON, OFF) Y2 Lock allows the Heat pump control to anticipate 2<sup>nd</sup> stage operation.

**Balance Point and Low Temperature Cut Out (LTCO):** Balance Point and LTCO settings determine how heating calls will be satisfied by the system.

If the outdoor temperature is **above** the balance point temperature setting, the auxiliary heat will not be used to satisfy the heating demand \*.

If the outdoor temperature is **below** the LTCO, the heat pump will not be used to satisfy the heating demand.

If the outdoor temperature is **between** both the balance point and the LTCO temperature settings, the thermostat will stage both heat pump and auxiliary heat as demand increases.

\*If after 4 hours the heating demand is not satisfied, auxiliary heat will be supplied. Reference communicating heat pump literature for more detail on heat pump operation.

## Airflow Configuration

The airflow configuration screens are available on systems that contain a communicating ID unit. Here the user can change delay profiles and airflow settings. CFM settings and ranges are defined by factory programmed values in the outdoor and indoor controls.

### IMPORTANT

*Changing airflow settings can effect system efficiency. Reference outdoor equipment tech guide for more information on system efficiencies.*

## Delay profile:

The delay profile is an airflow profile that the system will run in **COOL** mode. These profiles are not implemented in heating. Each profile is designed to accommodate the original environment where the equipment is installed.



To change the delay profiles press the box next to the profile that is desired (as pictured). Each of the profiles, (when selected) will provide a brief description of the profile design intent.

## Airflow Summary

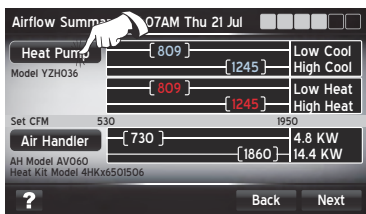

The airflow summary screen displays all current airflow settings at a glance. To edit the airflow settings press the indoor or outdoor button (heat pump or air handler shown).

## Airflow Configuration

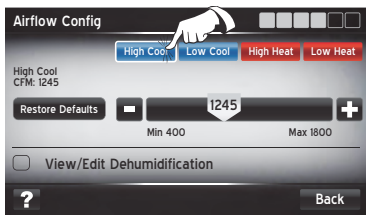

The airflow configuration screen shows the available airflow adjustments at the top of the screen (High Cool, Low Cool, High Heat, etc.). Simply press the desired adjustment to edit airflow.

Once in the desired airflow adjustment screen the user can adjust the airflow by CFM (in 10 CFM increments) by sliding the "homeplate" icon or pressing the "+" or "-" symbols.

The "**Restore Defaults**" button will return the airflow to the factory setting.

The "View/Edit Dehum" check box, when selected, will display the option to reduce the airflow by a selectable percentage when there is a call to dehumidify.

## ⚠ WARNING

*When changing airflow settings on electric heating components, the user should reference minimum CFM values required for operation (provided in the communicating air handler installation instructions).*

## Comfort Settings

This tool is available in all communicating systems. This screen is used to control comfort settings. These settings effect how the Touch Screen Communicating Control will satisfy calls for conditioning.

**Humidity Settings:** The humidity settings screen is used to change the humidify/dehumidify settings to fit the equipment installed.

### Humidification settings (Available only with humidifier installed)

**Humidification with a heat demand:** If this option is selected the control will only activate the humidifier if there is a demand for both heating and humidity.

**Humidification with or without a heat demand:** If this option is selected the control will activate the humidifier any time there is a humidity demand.

## NOTICE

*This is for use with hot water or steam humidifiers.*

**No Humidification:** The control will never activate the humidifier.

### Dehumidification settings

**De-Humidification with equipment:** If this option is selected the control will only dehumidify by running a reduced airflow on the indoor equipment (Available only with communicating indoor equipment).

**De-Humidification by overcooling:** If this option is selected the control will continue to run cooling up to 3 degrees below set point to meet humidity setting of the home (selectable from 1-3 degrees).

**De-Humidification with external equipment:** If this option is selected, there should be an external (whole home) de-humidifier.

## IMPORTANT

*This option may require a communication accessory control.*

**No De-Humidification:** If this option is selected the control will not send a command to de-humidify.

**Smart Recovery:** (ON, OFF) Smart recovery is used in programmable or advanced programmable mode. The controller initiates equipment operation, if required, before the start time of the program schedule day part. This is done to reach the program schedule event's desired temperature setpoint at the time the event occurs, rather than after.

**Temperature Control Settings:** Temperature Control Settings screen is used to customize how the Touch Screen Communicating Control will satisfy temperature set point. As well as, how the control will stage the installed equipment. The Touch Screen Communicating Control can be set up to satisfy demand differently depending on whether there is a heat demand or a cool demand.

Below is a table of explaining each of the available settings.

Variable	Default	Settings	Explanation
1 <sup>st</sup> Stage Differential	0.5	0.3, 0.5, 0.7, 1.0, 1.5, 2.0, 2.5, 3.0, 4.0, 5.0, 6.0, 7.0, 8.0	This is the difference between current temperature and set point for which the thermostat will command 1 <sup>st</sup> stage operation.
2 <sup>nd</sup> Stage Differential	0.5	0.3, 0.5, 0.7, 1.0, 1.5, 2.0, 2.5, 3.0, 4.0, 5.0, 6.0, 7.0, 8.0	This value Plus the 1 <sup>st</sup> stage differential is the value for which the thermostat will command 2 <sup>nd</sup> stage operation.
3 <sup>rd</sup> Stage Differential	0.5	0.3, 0.5, 0.7, 1.0, 1.5, 2.0, 2.5, 3.0, 4.0, 5.0, 6.0, 7.0, 8.0	This value Plus the sum of 1 <sup>st</sup> stage differential and the 2 <sup>nd</sup> stage differential is the value for which the thermostat will command 3 <sup>rd</sup> stage operation.
Minimum on timer	5 min.	1-5 min in 1 min intervals	Once a demand is present the thermostat will run for the selected Min on time.
Minimum off timer	5 min.	N/A	Once a demand is satisfied the thermostat will remain off for the Min off time.
Force stage up	90 min.	Off, 10 min, 20 min, 30 min, 60 min, 90 min, 120 min	If the forced stage up timer has been satisfied the control will stage up regardless of stage differential settings.
Stage Up Inhibit Timer	5 min.	5-60 min in 5 min intervals	If the stage inhibit timer has not been satisfied the control will not stage the equipment UP regardless of stage differential settings.
Allow Equipment to stage down?	Yes	Yes or No	This will give the thermostat the ability to stage down per temperature differentials.
Stage Down Inhibit Timer	5 min.	5-60 min in 5 min intervals	If the stage down inhibit timer has not been satisfied the control will not stage the equipment DOWN regardless of the stage differential settings.

**Auto Mode Deadband:** (4, 6, 8, 10) Auto mode deadband dictates the minimum temperature difference between the cooling and heating set point.

**Offset Settings:** (-5° – 5°) Offset setting allows the user to calibrate the displayed temperature and humidity from the measured temperature and humidity (indoor and outdoor) in the control.

**Control Settings:** Control settings screen is used to set “soft jumpers” on the installed communicating controls. Soft jumpers are settings that are conventionally set using a jumper on the control board, but are available to be set from the Touch Screen Communicating Control as well.

### **Equipment Temp Limits**

This screen allows the user to limit equipment functionality based on outdoor temperature.

The **Heating Temperature Limit**, when enabled, will not allow heating operation when the outdoor temperature rises above the setting.

The **Cooling Temperature Limit**, when enabled, will not allow cooling operation when the outdoor temperature drops below the setting.

## Ventilation Settings

The Ventilation Settings screens are used to view/edit settings associated with a whole home ventilator (ERV/HRV) devices. These screens are only accessible in system which have an ERV/HRV Accessory control installed. The settings available are explained in the table below.

### NOTICE

*The installer must also add the ventilation device through the Edit/Add device screen (as described previously).*

Variable	Default	Settings	Explanation
Ventilation Mode	Timed	Continuous, Timed or Off	This will determine how often the ventilation device will be opened
Ventilation Runtime per Cycle	20 min.	5-55 min in 5 min intervals	If ventilation mode is set to "Timed", the control will allow ventilation per this setting per Ventilation Cycle Time
Ventilation Cycle Time	1 hour	1 -4 hours	If ventilation mode is set to "Timed", the control will allow Ventilation Runtime per this setting
Ventilation Limits	Disabled	Disabled, Default, and Manual	If there is a damper installed for ventilation purposes
No Ventilation Above	100 F		The touch screen will not allow ventilation if the outdoor temperature exceeds this setting
No Ventilation Below	0 F		The touch screen will not allow ventilation if the outdoor temperatures is below this setting

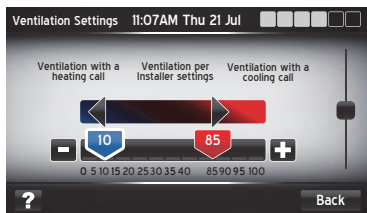

There are additional settings for ventilation that are covered with a temperature slider. These settings will determine if the ventilator is opened during a call for conditioning. The Touch Screen Communicating Control will open ventilation any time there is a call for conditioning if the outdoor temperature falls in the "Ventilation with a heating/cooling call". Otherwise ventilation will run with the indoor blower per the previously described settings.

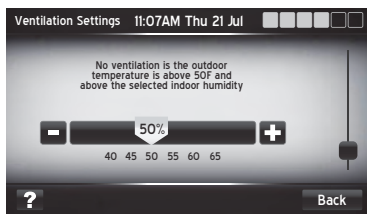

Finally the ventilation can be controlled per indoor humidity. If the outdoor temperature is above 50 degrees the touch screen can be set so that it will disable ventilation if the indoor humidity rises above the desired setting.

## **Float Switch Settings (AHV)**

This screen allows the user to activate the optional condensate float switch (S1-ACS2) and to determine how the outdoor equipment will shut down.

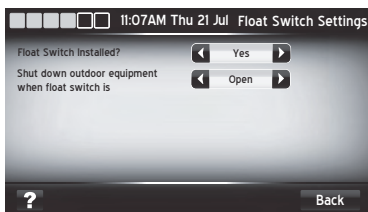

Variable	Default	Settings
Float switch installed?	No	Yes, No
Shut down outdoor equipment when float switch is:	Open	Open, Closed

## **2-Stage Variable Speed ECM Furnace Auxiliary Settings**

This screen allows the user to activate the optional condensate float switch (S1-ACS2) and/or the optional dry relay contact which is supplied by the utility company.

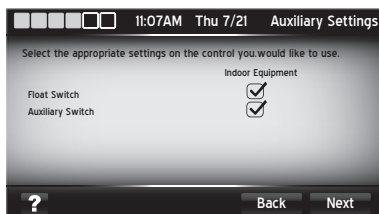

## **Float Switch Settings**

This screen allows the user to determine how the outdoor equipment will shut down.

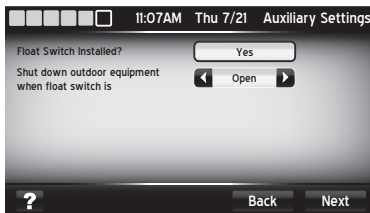

Variable	Default	Settings
Float switch installed?	Yes	Not Available
Shut down outdoor equipment when float switch is:	Open	Open, Closed



## Auxiliary Switch Settings

This screen allows the user to determine the functionality for cooling and heating.

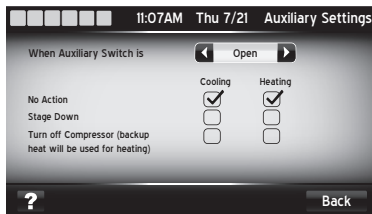

Variable	Default	Settings
When Auxiliary Switch is:	Open	Open, Closed

Available Functionality	Default
No Action	X
Stage Down	
Turn off Compressor (backup heat will be used for heating)	

## NOTICE

*Y2Lock must be OFF for the Stage Down Functionality.*

## Temperature Sensor

If used, this optional sensor is automatically detected during startup depending on the presence of an outdoor unit.

The Temperature Sensor is used as a Leaving Air Temperature Sensor if an outdoor unit is present and is used as an Outdoor Temperature Sensor if an outdoor unit is not present.

## Dealer Information

This tool is available in all communicating systems. This screen is used to view, import and edit the dealer information.

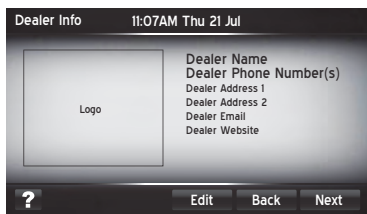

Once the “Dealer Information” button has been pressed in the “Tools and Settings” screen, the dealer information is displayed as previously input. To edit the information:

1. Press the “**edit**” button.
2. Press the field that you would like to edit.

3. The keyboard will “pop up” which is used to type name, address, e-mail, phone, and any other dealer information which will fit in the provided space.

To add a logo, simply press the “Add Logo” button and follow the instructions on the screen.

**NOTICE**

*The logo must be saved on a USB drive and plugged into the Touch Screen Communicating Control as described in the "Import/Export" section of these instructions.*

**NOTICE**

*The logo must be saved in the appropriate format using the configuration tool.*

In addition to manually entering dealer information at the thermostat, the dealer information can be added using the configuration tool. From the "Dealer Information" screen select the "Edit" button. Then select the "Import" button and plug the USB drive into the Touch Screen Communicating Control (as described in the "Import/Export" section of these instructions).

**Maintenance Reminder**

This "tool" is available in all communicating systems. This screen gives the user access to view, edit, enable, and disable maintenance reminders.

The maintenance reminder was designed to give an installer the opportunity to display a "maintenance needed pop up" to the homeowner on a specified date displaying the dealer information entered.

**NOTICE**

*This reminder could be used for seasonal system checkups or any other preventable maintenance that the dealer sees fit.*

**Administrator Tools**

This screen is used to access firmware update, firmware restart, and restore defaults.

**Firmware:**

The firmware button is used when there is a need to update the controller to a more recent program. To update the firmware:

1. Load the new firmware onto a USB drive.
2. Plug the drive into the Touch Screen Communicating Control as described in the "Import/Export" section of these instructions.
3. Press the "Firmware" button (on the Administrator tools screen).
4. The thermostat will locate the firmware file.

**CAUTION**

*Flashing new firmware will restore the Touch Screen Communicating Control to defaults. To prevent losing system settings: export "Installer Configuration" file before installing the new firmware. The installer configuration file can be imported after the firmware update to return the thermostats settings, schedule, dealer information, etc.*

**CAUTION**

*Do not remove the USB drive until the thermostat instructs you to do so. Failure to follow these instructions can cause your controller to perform erratically.*

**Restart Firmware:**

Restarting the firmware will simulate a power loss to the Touch Screen Communicating Control. This will restart the Touch Screen Communicating Control, which will validate all of the system settings and resume normal operation.

**Restore Defaults:**

Restoring defaults on the Touch Screen Communicating Control will return the control to its original factory settings. Upon re-boot, the control will run through auto setup screens as described earlier in this document. Restore defaults may be used when there is a System Miconfiguration that could be caused by a change in hard jumper settings or a change in equipment (which may include when an installer installs a furnace in the winter and then comes back in the spring to install an AC or heat pump).

**User Interface Settings**

This screen is used to customize homeowner access. There are several options to limit what the "homeowner" sees and how the touch screen will display.

To change a setting, simply press the desired box and a check mark will fill the selected setting (as pictured). To understand how these settings affect the functionality of the Touch Screen Communicating Control, reference the table below.

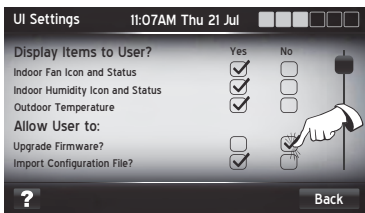
**NOTICE**

*When selecting "No" on this screen the installer is restricting what can be viewed/edited by the "Homeowner".*

Available Setting	If checked “Yes”
Indoor Fan Icon and Status	The fan icon and animation will be displayed on the touch screen dash.
Indoor Humidity Icon and Status	The humidity icon and animation will be displayed on the touch screen dash.
Outdoor Temperature	The outdoor temperature will be displayed on the touch screen dash.
Upgrade Firmware	The “homeowner” will have the ability to upgrade firmware.
Import Configuration File	The “homeowner” will have the ability import configuration settings.
Export Configuration File	The “homeowner” will have the ability export configuration settings.
Create a New Event in Log	The “homeowner” will have the ability to create a custom log entry.
View Details of Events in Log	The “homeowner” will have the ability to view fault and event details in the log.
Enable Security	The “homeowner” will have the ability to set and change pin settings to limit access to the touch screen
Change Sleep Screen	The “homeowner” will have the ability to select whether the touch screen displays the sleep screen after time out.
Select Advanced Programmable Mode	The “homeowner” will have the ability to select <b>Advanced Programmable</b> as a view mode from the menu screen.
Select Programmable Mode	The “homeowner” will have the ability to select <b>Programmable</b> as a view mode from the menu screen.
Import/Export Program Schedule	The “homeowner” will have the ability to import/export a saved schedule.

**⚠ CAUTION**

*Giving the homeowner the ability to “Upgrade Firmware” may require that the Touch Screen Communicating Control re-enter the auto-setup process. The installer should be sure that the homeowner is capable of this task before allowing this option. If the auto-setup is not executed properly, the system may not operate as desired.*

## Brand Selection



This screen is used to select the desired brand to be displayed on the Touch Screen Communicating Control. There are three brands to choose from: York, Coleman, and Luxaire. The touch screen is set by default to York. The brand selected will be displayed in the "sleep" screen as well as in the top right corner in several screens (as the service mode short cut).

## FORCED OPERATION: MASTER CONTROL



Forced operation is available in all communicating systems. The options and functions available depend on system ID. Forced operation (Located in the service mode menu screen) is a very powerful trouble shooting tool. This function allows the controller to command indoor and outdoor operation. Forced operation is separated into three different modes: Cool Mode, Heat Mode, IAQ Mode.

## NOTICE

*When entering forced operation, normal operation of the system will be discontinued. This means that the controller will not control equipment to maintain a set point, schedule, mode of operation, etc. Forced operation is a deviation from normal operation and the system will only run when commanded through the forced operation menus. Normal operation is restored when forced operation is exited.*



**Cool Mode:** Will test compressor cooling operation. This may include: 1<sup>st</sup> stage, 2<sup>nd</sup> stage cooling, and continuous fan operation.

**Heat Mode:** Will test compressor heating operation (if communicating heat pump is present), Furnace/Gas heating operation, and Electric/Air handler heating operation

**IAQ Mode:** Will test IAQ accessories that have been added to the system using the "Edit/Add Device" tool.

## NOTICE

*To force operation of IAQ equipment, an ERV/HRV interface control may be necessary.*

**CAUTION**

*Forced operation allows for abnormal operating conditions. This includes: bypassing anti-short cycle timers, forcing into and out of defrost, running air conditioner in low ambient temperatures, etc. The user should be aware of these conditions and proceed with caution.*

To force operation of the system:

1. Select the mode to test.
2. Select the length of time to test.

**NOTICE**

*The time selected can be bypassed anytime by pressing the "Stop" button.*

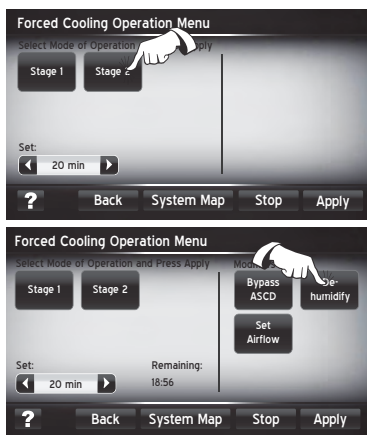

3. Select the "Operation" to be forced (and press "Apply" to start the operation).

Operations are on the left side of the screen. Operations available depend upon the force operation mode (Cool, Heat, or IAQ) and the system ID. For the most part, the operations include indoor and outdoor equipment staging and continuous fan.

4. Once the operation is selected, the timer will start to count down, and the modifiers will appear.
5. Select a modifier (if desired).

On the right side of the screen are the "modifiers". Modifiers are dependent upon the mode of operation selected (and will not appear until a mode has been selected and applied). Modifiers are additional "commands" that the controller can append to the current operation. In general, the modifiers will augment the operation to make more specific functionality.

6. Once the system is running as "forced", the user can press "System Map".

From the system map the user can access the equipment details, equipment status, and inputs/outputs screens along with the faults and log screen.

**NOTICE**

*Remember, on screens that contain information which varies dynamically, a "Refresh" button is available. Pressing the refresh button will insure that all information being displayed is current.*

7. To return to the Forced operation menu from system map, press "Menu"
8. To leave forced operation, navigate by pressing the "back" button to the forced operation main menu screen and press "Exit".

When leaving forced operation, the system will discontinue the "forced" operation and resume "normal" operation.

## Exiting Service Mode



To exit service mode, press the button in the upper, right hand corner of the system map screen. When the exit button is pressed, the Touch Screen Communicating Control will re-validate and return to normal operation.

## SERVICE TOOL SETUP

The service tool application is defined as a Touch Screen Communicating Control that is being used to trouble shoot/view details of a system. The Touch Screen Communicating Control can access the system from the indoor and the outdoor controls via the communication ports outlined earlier in this document.

### NOTICE

*While the service tool is highly useful device mode, the Touch Screen Communicating Control that has been configured as the "master" of the communicating system contains all the information available for trouble shooting purposes while the service tool function may have some limitations.*

To set up the service tool for operation:

1. Extend wire harness.

### Extending the Communication Harness

Each Touch Screen Communicating Control is supplied with a communicating plug harness. This harness is 18" long and can be extended with thermostat wire to allow more convenient and safe use of the service tool.

To extend the harness:

- a. Use 5-6 feet of thermostat wire (enough to maintain a safe/comfortable distance from the high voltage in the control panels) and 4 wire nuts.
- b. Use the wire nuts to connect the stripped ends of the communicating plug harness to the loose/stripped ends of the thermostat wire.
- c. Wire the non-plug end of the extended harness to the terminal block of the mounting back plate of the Touch Screen Communicating Control.
- d. Snap the Touch Screen Communicating Control on the back plate.

### WARNING

#### **ELECTRICAL OPERATION HAZARD**

*Failure to follow this warning could result in personal injury, death, or equipment damage. Before installing, modifying, or servicing system, the main electrical disconnect switch must be in the OFF position. There may be more than 1 disconnect switch. Lock out and tag switch with a suitable warning label.*

2. Disconnect power to the entire system that you wish to access a communications port (communication ports are outlined in the wiring section of this document).
3. Once power is disconnected, plug the harness into one of the communicating terminals. Routing the harness so that the power can be re-applied (allowing for the door switches etc. where applicable)

**⚠ CAUTION**

*The control housings contain areas of high voltage. Always assure, when trouble shooting the system, that a safe distance is maintained from high voltage. Below are illustrations that show some of the high voltage areas.*

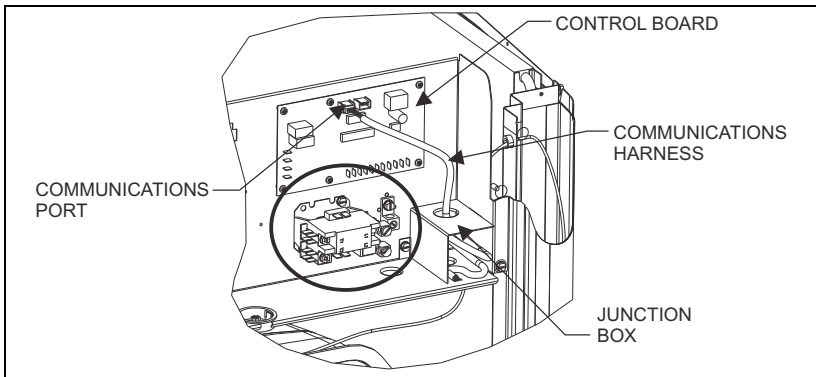

**FIGURE 16:** Outdoor Unit Communicating Terminals

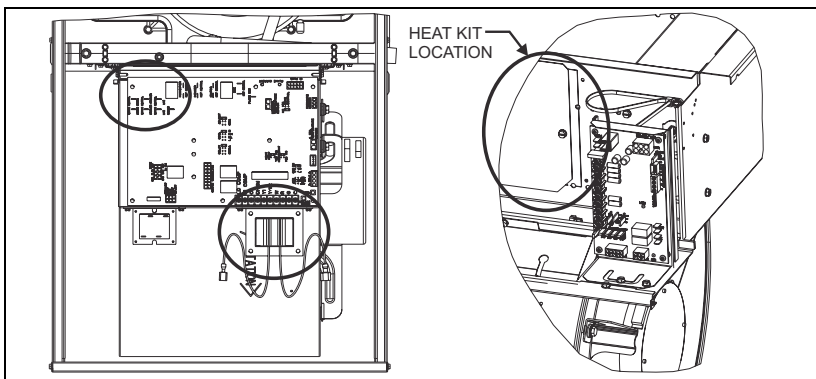

**FIGURE 17:** High Voltage Locations



- Place touch screen down in a safe/dry space (away from fan blades, condensation, etc.).

## ⚠ CAUTION

*Failure to ensure the Touch Screen Communicating Control is safely placed may cause damage to the device.*

- Return power to the entire system.
- The Touch Screen Communicating Control will commence the start up sequence (as outlined previously).

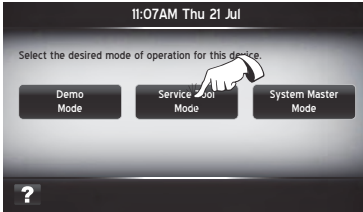

- Select the service tool option when prompted.

### Navigating Service Mode: Service Tool

Service mode screens on the service tool are the same as described before. However, there is some functionality of service mode that is not available on the service tool. The following outlines what is available from the service tool.

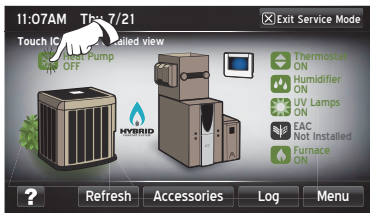

The system map displayed on the service tool has all of the information that the master displays. This includes pressing the equipment icons and viewing: Equipment Details, Status, and Inputs/Outputs screens.

### Log Button: Service Tool



The log button is available in service mode. The user **will not** be able to enter a new log event or clear log entries. The other functions of log are available and are outlined in the Log Button: Master Control section of this document.

## Menu Button: Service Tool

When using the service tool, the installer only has access to the force operation feature.

## Forced Operation: Service Tool

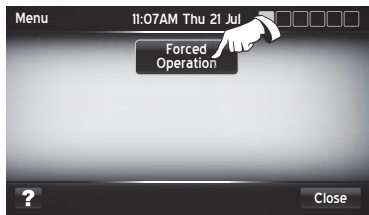

Forced operation on the service tool is fully functional. However, when viewing the system map while forcing operation, the same limitations of the log and system map exist.

To view more information about forcing system operation, view the "Forced Operation: Master Control" section.

## Exiting Service Tool

To exit service mode, simply remove power from the device. This will reset the software and return the Touch Screen Communicating Control to original settings.

## Demo Mode Setup

The Demo Mode application is defined as a Touch Screen Communicating Control that is being used to simulate connection to a communicating system. While in demo mode, the control will allow the user to choose the type of equipment to be displayed and the Touch Screen Communicating Control will present as though the system components are connected.

### **NOTICE**

*Demo mode will simulate a fault every 5 minutes.*

*Demo mode only requires 24 VAC on the R and C terminals.*

*While the Touch Screen Communicating Control is configured in Demo Mode, other communicating controls will not receive commands. **Demo Mode will not control a communicating system.***